

Truck Mounted Attenuators

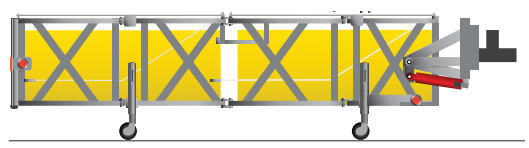

SS90™ HD



TRINITY
HIGHWAY
Ahead of the Curve™

SS90™ HD

The SS90™ HD is a heavy duty, truck mounted attenuator (TMA) for use on stationary or moving shadow support vehicles. This TMA has passed all mandatory and optional testing and is NCHRP Report 350 Test Level 3 compliant. Additionally, the SS90 HD has passed the UK TD 49, 110 km/h (68 mph) test. The unit is comprised of two light-weight aluminum cartridges contained in a potentially reusable galvanized support frame. The SS90 HD helps to absorb rear-end impacts at speeds up to 62 mph (100 km/h) when impacted according to NCHRP 350 crash test standards.

Assembly and Maintenance

- Simple attachment options mount to standard truck
- Mounting options include socket hitch and tailgate mount
- Hand crank jacks and swivel casters allow for easy stable mounting, dismounting and moving for storage

HEAVY DUTY

Features

- Galvanized, potentially reusable steel frame and components. Black and yellow powder coated systems available upon request.
- Replaceable energy absorbing cartridges.
- High temperature rated, powerful hydraulic system quickly lowers and raises TMA for storage and transport.
- Accessible hydraulic pump and reservoir promotes easy inspection and maintenance.
- Custom lighting systems available in 12V, 24V, Incandescent or LED systems. Easy, cable routing and mounting locations ensure quick assembly.
- “Push-to-activate” function raises and lowers unit. An alert buzzer sounds when unit is not fully deployed or in vertical position. In-cab controls also available.
- Can withstand typical low-speed nuisance hits up to 6 mph (10 km/h).

Specifications

- 13'2" (3.98 m) Length From Back of Truck
- 7'9" (2.36 m) Wide
- 1,996 lbs (906 kg)
- 12" (3,055 mm) Road Clearance
- 16,090 lbs (7,300 kg) Minimum Support Vehicle Weight

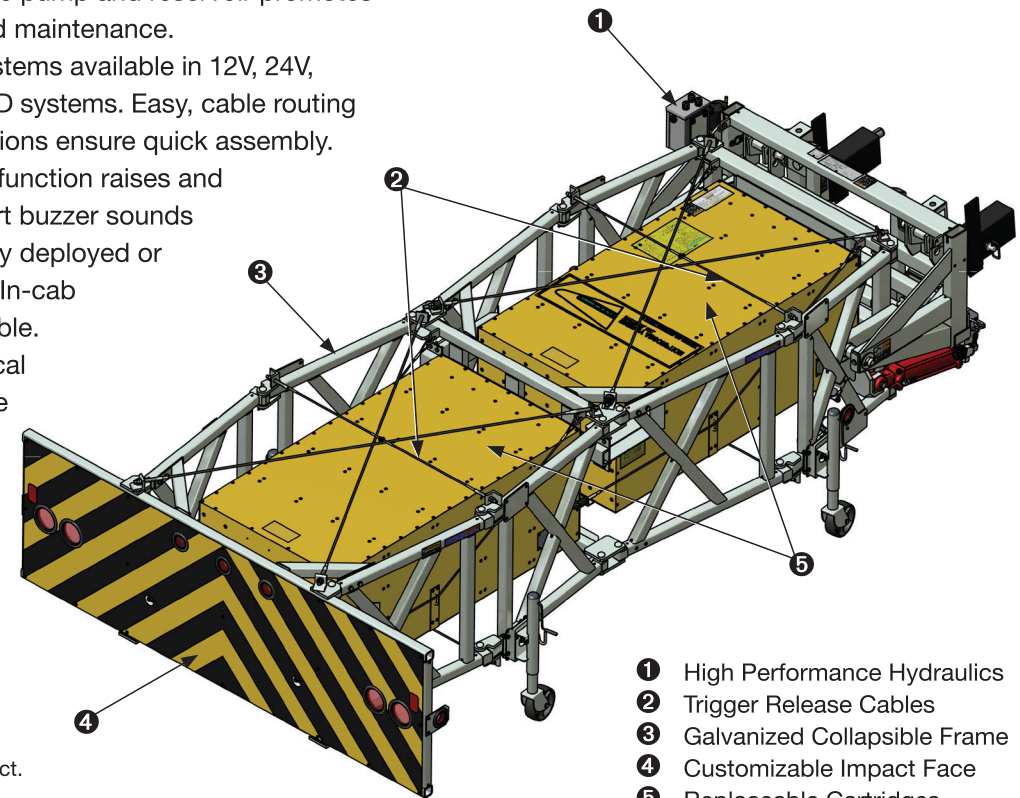

An original  ENERGY ABSORPTION SYSTEMS, INC. product.

Distributed by:

 **Coral Sales Co.**
Highway Safety Solutions

P. 503-655-6351 » F. 503-657-9649

www.coralsales.com

PO Box 22385 Portland, OR 97269-2385

1-14

www.trinityhighway.com

1.888.323.6374

