



**QuadGuard[®] High Speed
(HS)**



TRINITY
HIGHWAY
Ahead of the Curve[®]

QuadGuard® High Speed (HS)

The QuadGuard® High Speed (HS) system is a redirective, non-gating crash cushion that consists of three space frames, six standard diaphragms, and crushable energy absorbing cartridges, all surrounded by a framework of steel Quad-Beam™ panels. The system is tested to NCHRP Report 350 Test Level 3. The QuadGuard® HS can be used to shield fixed objects 24", 30", and 36" wide.

The QuadGuard® HS, as a member of the QuadGuard® family of crash cushions, consists of many of the same components as the QuadGuard.

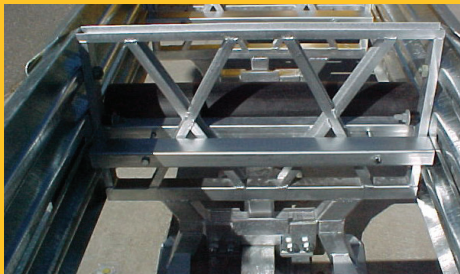

Space-Frame Diaphragm

Features

- Flex-belt nose.
- Replaceable energy absorbing cartridges.
- Lightweight space-frame diaphragms in the first three bays.
- High strength Quad-Beam™ panels.
- Does not use anchoring chains or tension cables.
- Custom connections available.
- Compact, modular design tested to 70 mph (113 km/h).

Assembly and Maintenance

- Interchangeable components help reduce repair costs.
- Anchorage options include both asphalt and concrete.
- Major components are potentially reusable after an impact within NCHRP Report 350 crash test standards.*

Back-Up Structure and Attachments

- Simplified backups – Tension strut or concrete
- Bridge pier(s) and parapet(s)
- Concrete gores
- Temporary and permanent concrete barrier(s)
- Thrie-beam end sections
- W-beam end sections

Specifications

Nine-Bay Unit

(Available in widths of 24", 30" & 36")

- 3,700 lbs. (1,678 kg)
- Length: 30' (9,144 mm)
- Shields fixed objects up to 36" in Width

- 1 Self-Supporting Nose
- 2 Space-Frame Diaphragms (First Three Diaphragms)
- 3 Standard Diaphragm
- 4 Replaceable Cartridge
- 5 Quad-Beam Panel
- 6 Backup

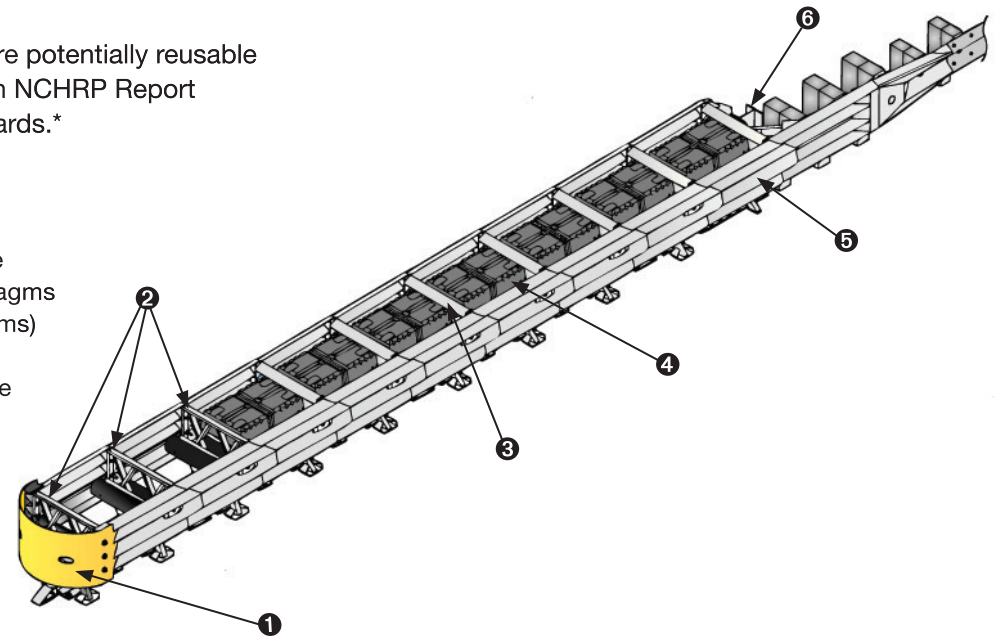

An original  product.

Distributed by:

 **Coral Sales Co.**
Highway Safety Solutions

P. 503-655-6351 » F. 503-657-9649

www.coralsales.com

PO Box 22385 Portland, OR 97269-2385

4-19

www.trinityhighway.com
1.888.323.6374

